

JAY•LOR[®] *BECAUSE
NUTRITION
MATTERS.*[™]

PARTS BOOK

5150 STATIONARY MIXER

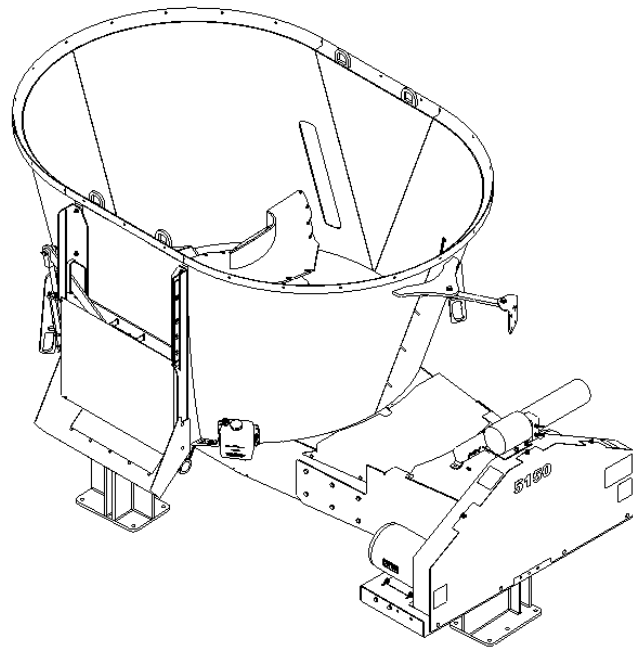

"Because Nutrition Matters™"

Jaylor

071213 10th Line, East Garafraxa, Ontario, L9W6Z9 Tel: (519) 787-9353 Fax: (519) 787-7053

TABLE OF CONTENTS

A.	INTRODUCTION	2
B.	CONTACT INFORMATION.....	2
C.	GENERAL INFORMATION	2
D.	PART NUMBERING SYSTEM	3
E.	SERIAL NUMBER LOCATION	3
F.	DRUM.....	4
	Door Tracks & Shields	5
	Door Arm	6
	Discharge Chute	7
	Door Hydraulics	8
	Viewing Window	9
	Restrictor Blades	10
	Extension.....	11
G.	FRAME.....	12
	Platform Exterior	13
	Platform Interior	14
	Feet & Mounts.....	15
H.	AUGER.....	16
	Auger & Knives.....	17
I.	DRIVELINE	18
	Front PTO	19
	Gearbox Oil Reservoir	20
	Gearbox Exterior	21
J.	SCALE	22
	Scale System	23

A. INTRODUCTION

This Dealer Copy of the Parts Book contains common and general information applicable to the Jaylor Manure Spreaders. It has been carefully designed to ensure that correct and accurate information is portrayed in every area of a typical unit, enabling efficient and effective service to the end user of Jaylor's products.

The format of this book consists of a fundamental breakdown of components and assemblies according to the area in which they are located or function on the machine. Each area of section contains illustrative information regarding a part or an assembly, along with information such as part numbers and quantities included. For details and pricing information regarding parts and assemblies depicted in the illustrations please contact Jaylor. Our service personnel will be more than willing to assist you in obtaining information as it pertains to Jaylor's line of products. Information and pricing for non-stock and/or custom items will be quoted on request.

Note:

Parts and assemblies in this book may not be exactly as shown. Jaylor reserves the right to make any changes/revisions/amendments at any time as deemed necessary to ensure that correct information is provided.

B. CONTACT INFORMATION

Contact Jaylor at:



**071213 10th Line
East Garafraxa, ON
Canada
L9W 6Z9**

Phone: (519) 787-9353
Fax: (519) 787-7053
E-mail: jaylor@jaylor.com
On the web: www.jaylor.com

C. GENERAL INFORMATION

It is important to use extreme caution when performing any type of service to this equipment. General information regarding service procedures and intervals is covered in the Owner Manual provided with the new product. For more specific product service, please contact Jaylor to obtain Technical Service Bulletins that outline the procedures and requirements for such.

It is also important to ensure that only Jaylor genuine or approved parts are to be used where applicable. Mismatched or incorrect components can result in machine damage or malfunction, or possibly personal injury.

D. PART NUMBERING SYSTEM

Jaylor's part numbering system consists of eleven digits as shown below:

XXX-000-12345

The first three digits are the **Product Group Code** (PGC), which consists of three alpha characters which will be referred to as (XXX). The next three numeric digits will be referred to as (000) and represent the **Product Code** (PC). The next five numeric digits represent the **Part Number** (PN) and are referred to as (12345).

The Product Code (PC) follows the following numbering convention:

PC	Description
000	Universal Parts
101	Box Parts
102	Frame / Chassis Parts
103	Ladder Parts
104	Wheel / Hub / Axle Parts
105	Beater Parts
106	Spreader Rear End Parts
107	Driveline Parts
109	Hydraulic and Pneumatic Parts
112	Decals
118	Electrical / Lighting Parts

E. SERIAL NUMBER LOCATION

When ordering components for Jaylor products it is important to include the machine model and serial numbers if applicable. The serial number plate is located on the frame of the machine as indicated in the diagram below:

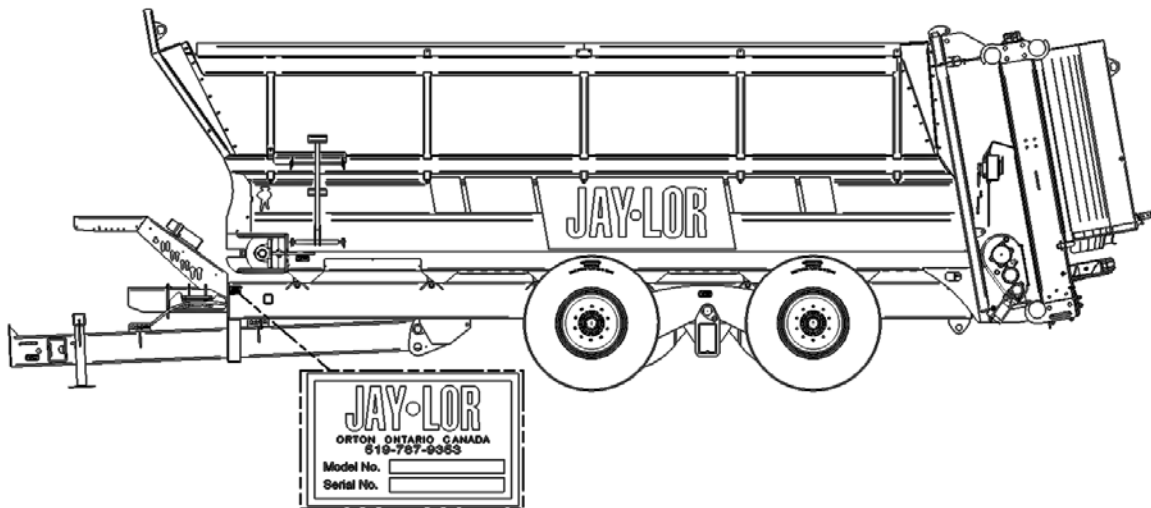

F. DRUM

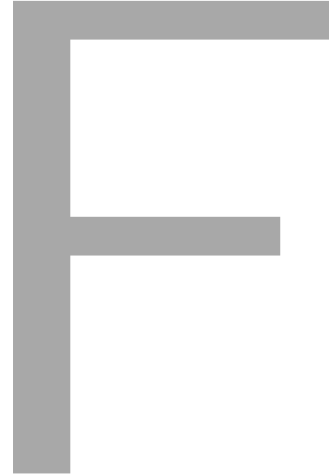

DOORS & SHIELDING

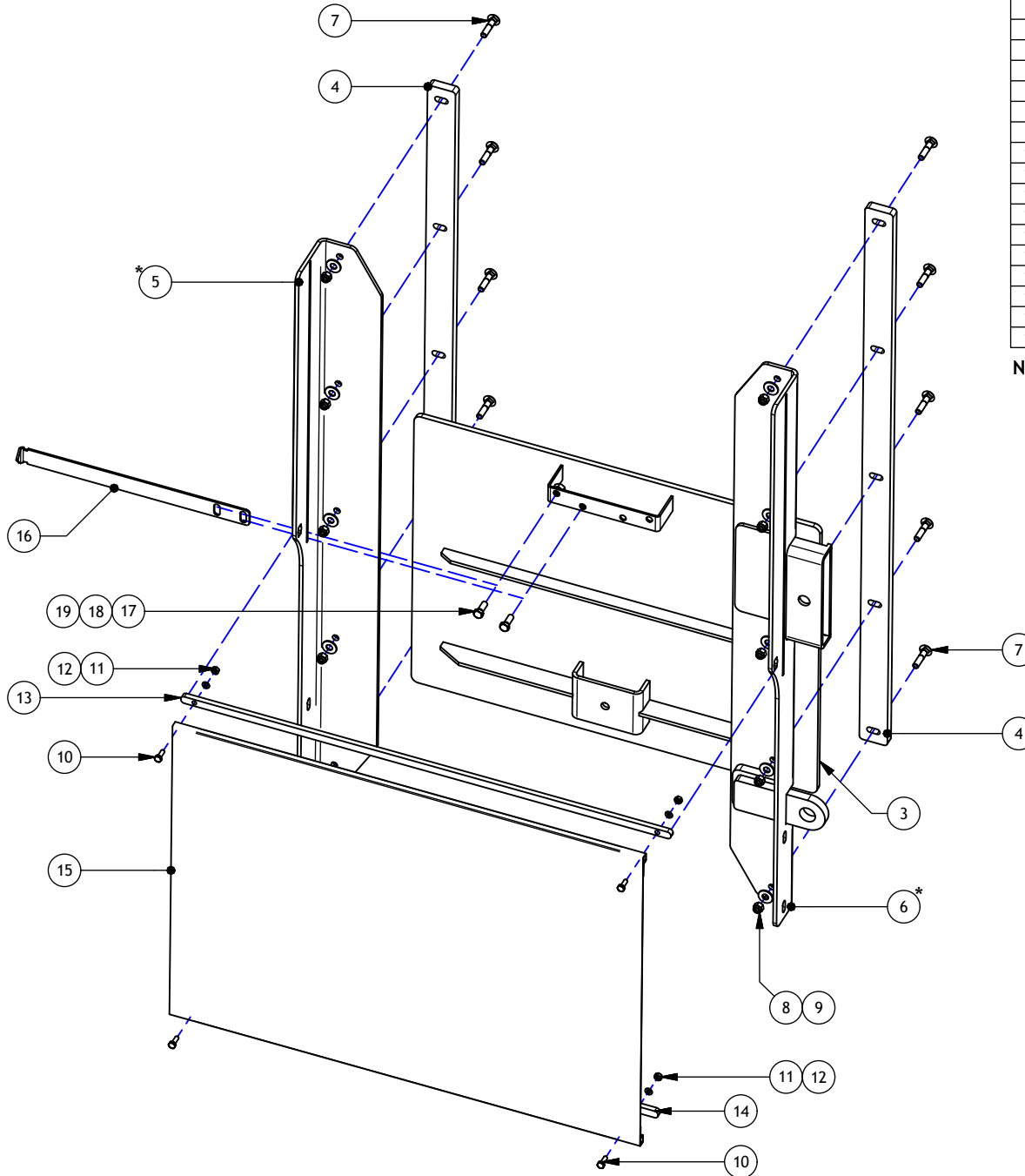

* FRONT RIGHT DOOR ILLUSTRATED.
DOOR TRACK PART NUMBERS CHANGE DEPENDING ON LOCATION OF DOOR.

Parts List			
ITEM	PART NUMBER	TITLE	QTY
1	AAA-001-02099	C-SIDE DOOR TRACK WELDMENT (FRT LTH OR REAR RTH) (5150/5275)	1
2	AAA-001-02097	C-SIDE DOOR TRACK (FRT LTH OR REAR RTH) (5150/5275)	1
3	AAA-001-02093	C-SIDE DOOR WELDMENT (5150/5275)	1
4	AAA-001-02088	C-SIDE DOOR SPCR 5/8T (5150/5275)	2
5	AAA-001-02081	C-SIDE DOOR TRACK (FRT RTH OR REAR LTH) (5150/5275)	1
6	AAA-001-02087	C-SIDE DOOR TRACK WELDMENT (FRT RTH OR REAR LTH) (5150/5275)	1
7	AAB-015-10171	BOLT CARRIAGE 3/8 X 1-3/4 UNC GRD 5	10
8	AAB-015-20012	NUT HEX 3/8 LOCK NYLON GRD 2	10
9	AAB-015-30012	WSHR FLAT 3/8 USS	10
10	AAB-015-10089	BOLT HEX 1/4 X 3/4 UNC GRD 5	4
11	AAB-015-20036	NUT HEX 1/4 UNC GRD 5	4
12	AAB-015-30025	WSHR FLAT 1/4	4
13	AAA-001-02105	C-SIDE SHIELD UPRR CROSS BAR 35L X 3/8T (5150/5275)	1
14	AAA-001-02106	C-SIDE SHIELD LWR CROSS BAR 33.625L X 3/8T (5150/5275)	1
15	AAB-001-00051	C-SIDE TARP DISCHARGE SHIELD 40 OZ (5275)	1
16	AAA-001-02115-P3	C-SIDE DOOR HEIGHT INDICATOR 1/8T (5150/5275) (BLACK)	1
17	AAB-015-10056	BOLT HEX 3/8 X 1 UNC GRD 2	2
18	AAB-015-30017	WSHR LOCK 3/8	2
19	AAB-015-20017	NUT HEX 3/8 UNC GRD 2	2

NOTE: PART QUANTITIES ARE PER DOOR

5150ST DOOR LOCATIONS

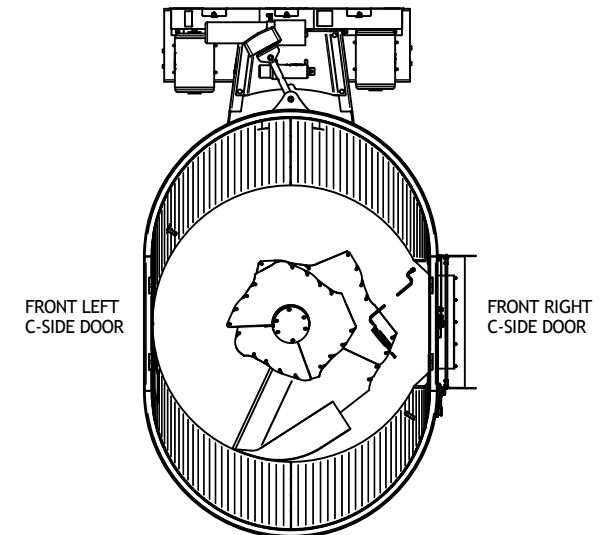

DRAWN : CDiRamio		TOLERANCES (UNLESS SPECIFIED OTHERWISE)
DATE : 8/30/2016		FRACTIONAL ± 1/16"
FILE : AAA-054-00407		DEC X.X ± 0.1"
TITLE : 5150ST DOORS & SHIELDING		DEC X.XX ± 0.06"
PRINT DATE: 11/4/2016	SHEET 1 OF 1	DEC X.XXX ± 0.031"
<small>CONFIDENTIAL: THESE DRAWINGS AND COPIES THEREOF REMAIN THE PROPERTY OF JAY-LOR FABRICATING INC. ANY PERSON FOUND UNLAWFULLY USING, DISTRIBUTING, OR IN POSSESSION OF THE ABOVE WILL BE PROSECUTED</small>		

Parts List			
ITEM	PART NUMBER	TITLE	QTY
1	AAA-001-02101-P3	DOOR ARM (FRT RTH OR REAR LTH) (5150/5275) (BLACK)	1
2	AAA-001-02108-P3	DOOR ARM (FRT LTH OR REAR RTH) (5150/5275) (BLACK)	1
3	AAA-001-02102-P3	DOOR LINKAGE 1/2T (5150/5275) (BLACK)	1
4	AAB-015-10079	BOLT HEX 3/4 X 3 UNC GRD 5	1
5	AAB-015-10133	BOLT HEX 1/2-13 X 2-1/4 GRD 5	2
6	AAB-015-20016	NUT HEX LOCK NYLON 3/4 UNC GRD 8	1
7	AAB-015-20019	NUT NYLON LOCK 1/2 UNC GRD 5	2
8	AAB-015-30013	WSHR FLAT 1/2 USS	4
9	AAB-015-30015	WSHR FLAT 3/4 USS	2
10	AAB-015-30034	WASHER NYLON 1/2ID X 1-1/4OD X 1/8T	4

NOTE: PART QUANTITIES ARE PER DOOR

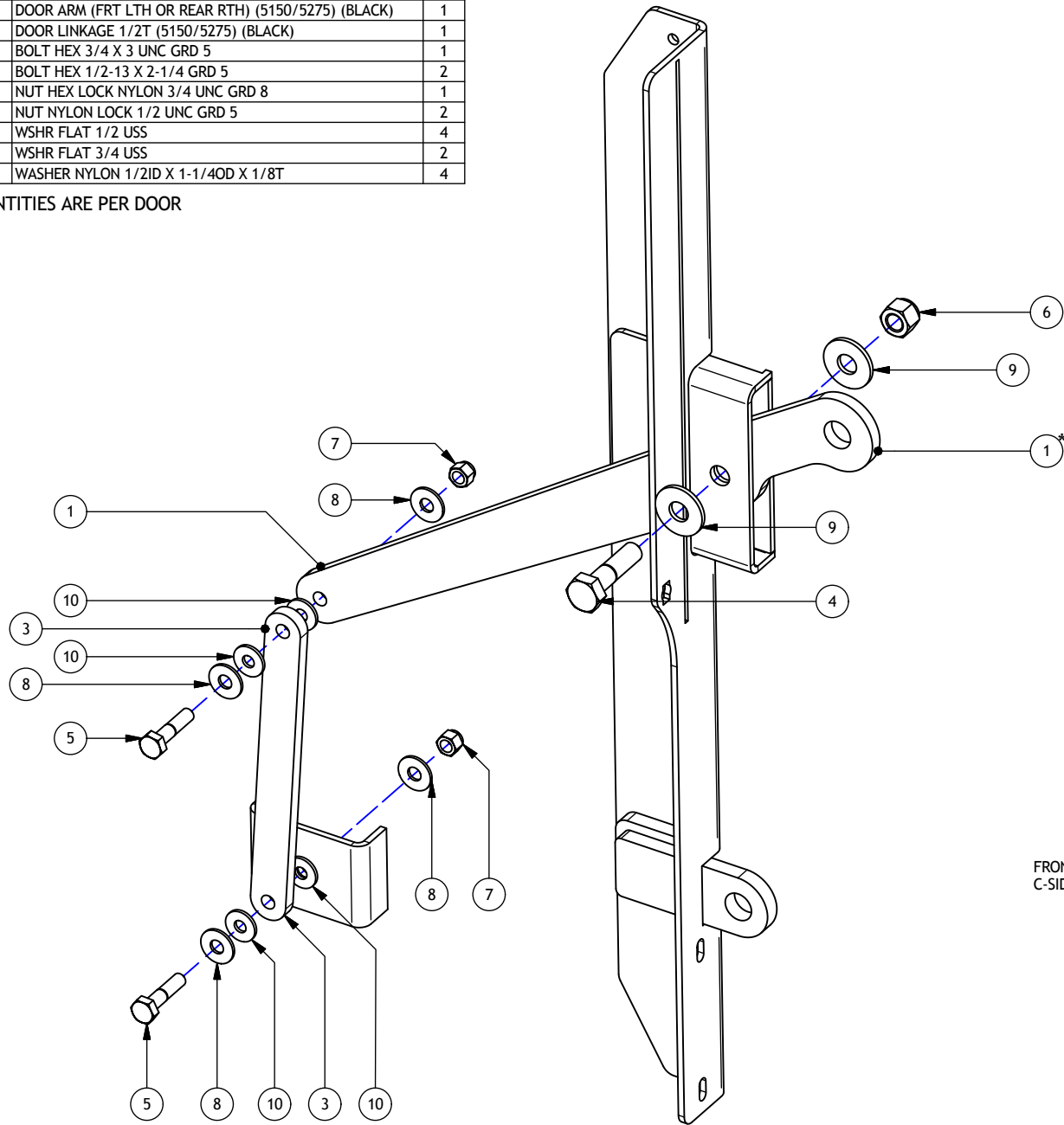

* FRONT RIGHT DOOR ARM ILLUSTRATED.
DOOR ARM PART NUMBERS CHANGE DEPENDING ON LOCATION OF DOOR.

DOOR ARMS

5150ST DOOR LOCATIONS

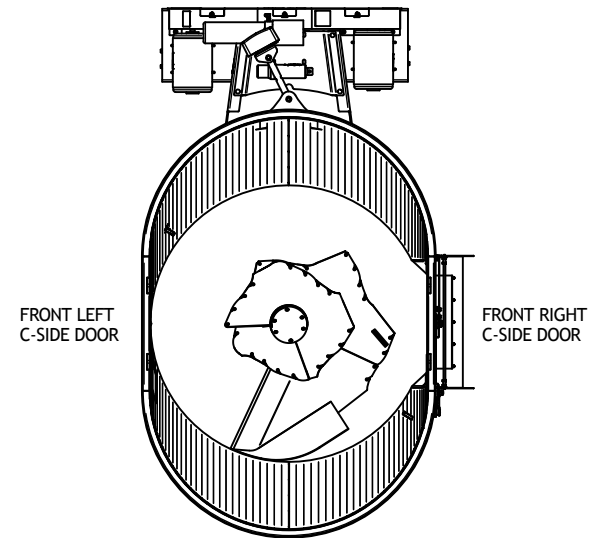

DRAWN : CDiRamio	JAY-LOR Fabricating Inc	TOLERANCES (UNLESS SPECIFIED OTHERWISE)
DATE : 8/30/2016		FRACTIONAL ± 1/16"
FILE : AAA-054-00408		DEC X.X ± 0.1"
TITLE : 5150ST DOOR ARMS		DEC X.XX ± 0.06"
		DEC X.XXX ± 0.031"
		ANGULAR ± 0.5°
PRINT DATE: 11/7/2016	SHEET 1 OF 1	
CONFIDENTIAL: THESE DRAWINGS AND COPIES THEREOF REMAIN THE PROPERTY OF JAY-LOR FABRICATING INC. ANY PERSON FOUND UNLAWFULLY USING, DISTRIBUTING, OR IN POSSESSION OF THE ABOVE WILL BE PROSECUTED		

Parts List

ITEM	PART NUMBER	TITLE	QTY
1	AAA-006-00321C	MAGNET CHUTE BLANK PLT 1/8T	1
2	AAA-006-01178	C-SIDE CHUTE 1/8T (5150/5275)	1
3	AAB-015-10060	BOLT CARRIAGE 3/8 X 1-1/4 UNC GRD 2	4
4	AAB-015-20017	NUT HEX 3/8 UNC GRD 2	4
5	AAB-015-20020	NUT HEX 5/16 UNC GRD 2	10
6	AAB-015-30012	WSHR FLAT 3/8 USS	4
7	AAB-015-30016	WSHR LOCK 5/16	10
8	AAB-015-30017	WSHR LOCK 3/8	4

NOTE: PART QUANTITIES ARE PER CHUTE

Kit List

PART NUMBER	DESCRIPTION
AAA-006-01179	C-SIDE CHUTE ASSY KIT (5150/5275)
KIT CONTENTS	1 C-SIDE CHUTE 1 BLANK PLATE 4 CARRIAGE BOLTS (3/8" X 1-1/4") 10 HEX BOLTS (5/16" X 3/4") 14 LOCK WASHERS (4 - 3/8", 10 - 5/16") 4 FLAT WASHERS (3/8") 14 HEX NUTS (4 - 3/8", 10 - 5/16")
PART NUMBER	DESCRIPTION
AAA-006-01180	C-SIDE MAGNET CHUTE ASSY KIT (5150/5275)
KIT CONTENTS	1 C-SIDE CHUTE 1 MAGNET PLATE 4 CARRIAGE BOLTS (3/8" X 1-1/4") 10 HEX BOLTS (5/16" X 3/4") 14 LOCK WASHERS (4 - 3/8", 10 - 5/16") 4 FLAT WASHERS (3/8") 14 HEX NUTS (4 - 3/8", 10 - 5/16")

C-SIDE DOOR CHUTE

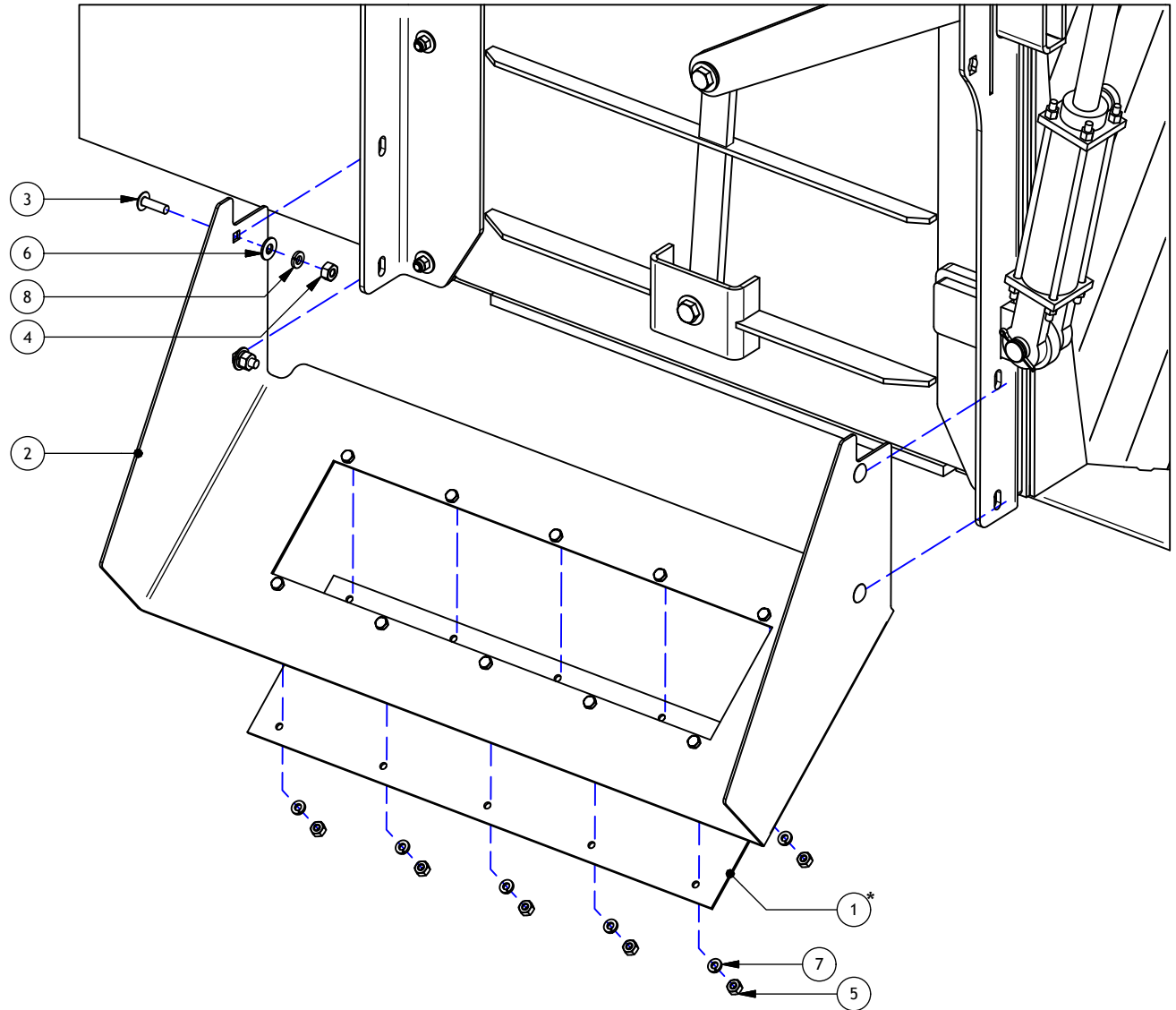

* NON-MAGNET CHUTE ILLUSTRATED.
PART NUMBER FOR MAGNET CHUTE PLATE: AAB-006-00035.

DRAWN : CDiRamio		TOLERANCES (UNLESS SPECIFIED OTHERWISE)
DATE : 8/30/2016		FRACTIONAL ± 1/16"
FILE : AAA-054-00350		DEC X.X ± 0.1"
TITLE : 5150ST/5275ST C-SIDE DOOR CHUTE		DEC X.XX ± 0.06"
PRINT DATE: 11/7/2016		DEC X.XXX ± 0.031"
		ANGULAR ± 0.5°
SHEET 1 OF 1		
<small>CONFIDENTIAL: THESE DRAWINGS AND COPIES THEREOF REMAIN THE PROPERTY OF JAY-LOR FABRICATING INC. ANY PERSON FOUND UNLAWFULLY USING, DISTRIBUTING, OR IN POSSESSION OF THE ABOVE WILL BE PROSECUTED</small>		

C-SIDE DOOR HYDRAULICS

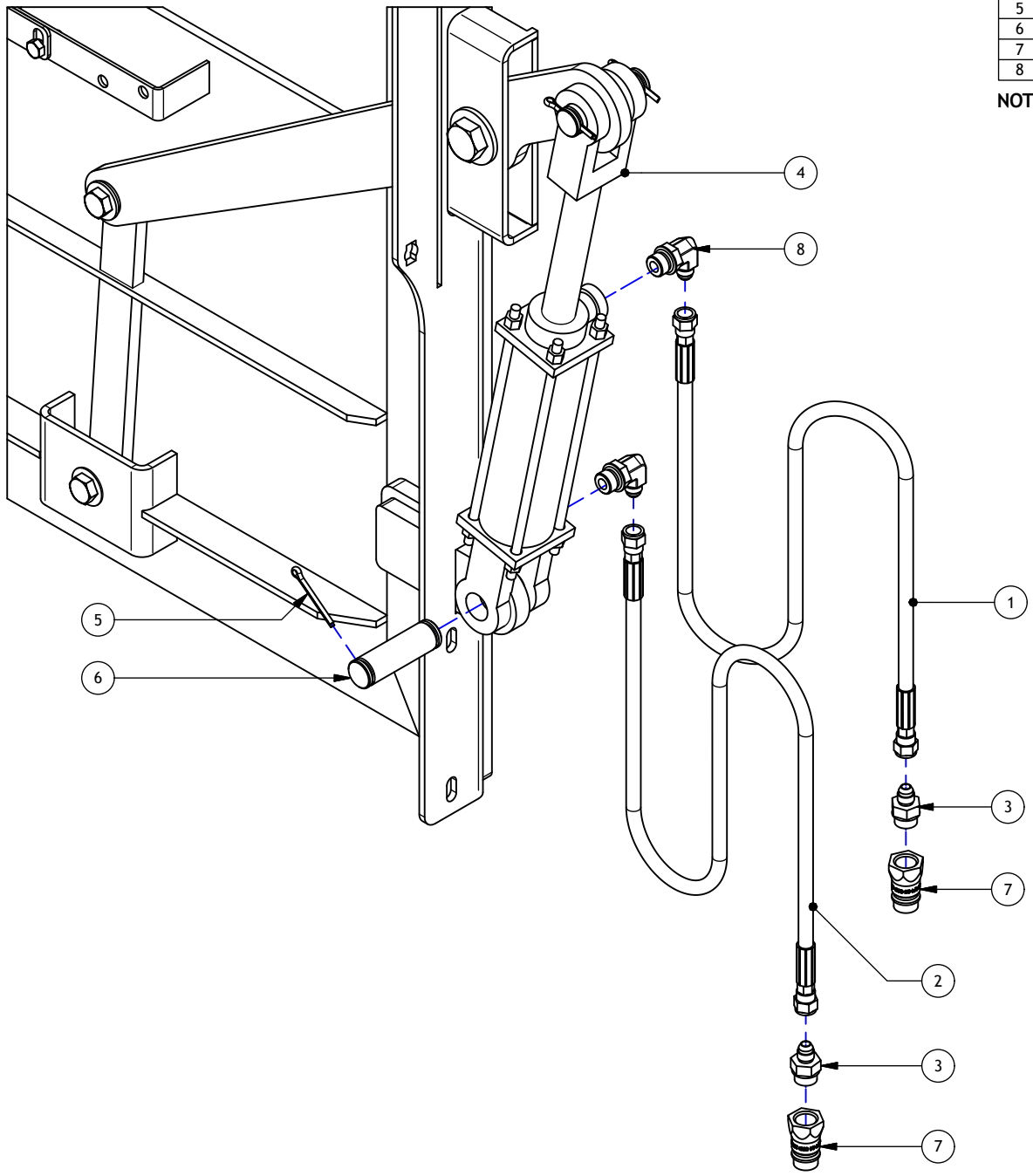

Parts List			
ITEM	PART NUMBER	TITLE	QTY
1	AAA-009-00948	HOSE HYD 1/4DIA SINGLE BRAID 6 FJIC SWIVEL X 6 FJIC SWIVEL 170L	1
2	AAA-009-00949	HOSE HYD 1/4DIA SINGLE BRAID 6 FJIC SWIVEL X 6 FJIC SWIVEL 159L	1
3	AAB-009-00074	FIT ADPT 6 MJIC X 8 MORB	2
4	AAB-009-00230	HYD CYL 6IN STROKE X 2IN BORE	1
5	AAB-007-00149	COTTER PIN 3/16 X 1-3/4	4
6	AAB-015-00002	CLEVIS PIN 1"DIA	2
7	AAB-009-00322	FIT 8 MQDC X 8 FORB BALL STYLE	2
8	AAB-009-00352	FIT 90DEG 6 MJIC X 8 MORB ADJ	2

NOTE: PART QUANTITIES ARE PER DOOR

DRAWN : CDiRamio		TOLERANCES (UNLESS SPECIFIED OTHERWISE)
DATE : 8/30/2016		FRACTIONAL ± 1/16"
FILE : AAA-054-00409		DEC X.X ± 0.1"
TITLE : 5150ST C-SIDE DOOR HYDRAULICS		DEC X.XX ± 0.06"
PRINT DATE: 11/7/2016	SHEET 1 OF 1	DEC X.XXX ± 0.031"
<small>CONFIDENTIAL: THESE DRAWINGS AND COPIES THEREOF REMAIN THE PROPERTY OF JAY-LOR FABRICATING INC. ANY PERSON FOUND UNLAWFULLY USING, DISTRIBUTING, OR IN POSSESSION OF THE ABOVE WILL BE PROSECUTED</small>		

Parts List			
ITEM	PART NUMBER	TITLE	QTY
1	AAB-001-00037	WNDW VIEWING	1
2	AAB-015-10144	BOLT HEX SELF-TAPPING 1/4-20 X 1/2L GRD 5	1

VIEWING WINDOW

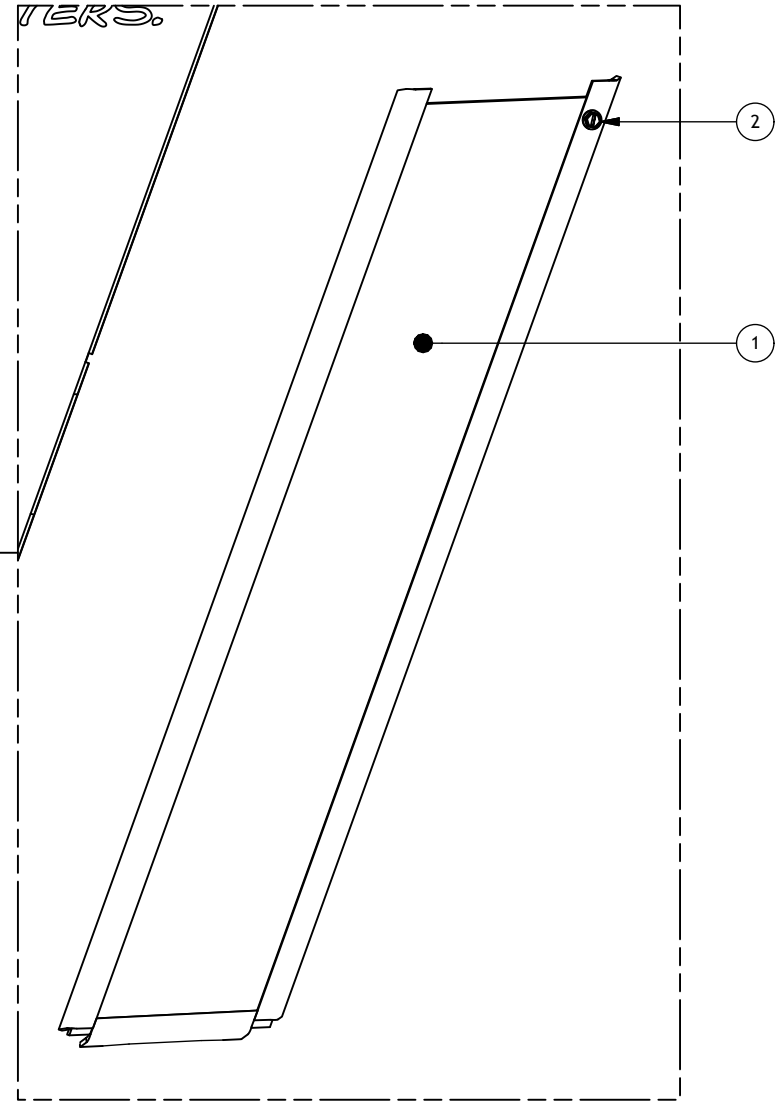
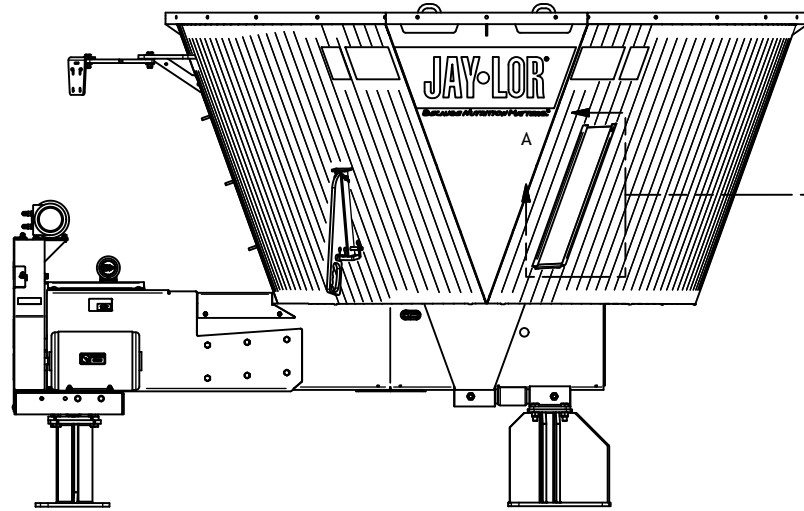

* RIGHT C-SIDE DOOR CONFIGURATION ILLUSTRATED.
WINDOW WILL BE LOCATED ON OPPOSITE SIDE OF MIXER
FOR LEFT C-SIDE DOOR CONFIGURATION.

DRAWN : CDiRamio		TOLERANCES (UNLESS SPECIFIED OTHERWISE)
DATE : 8/24/2016		FRACTIONAL ± 1/16"
FILE : AAA-054-00411		DEC X.X ± 0.1"
TITLE : 5150ST VIEWING WINDOW		DEC X.XXX ± 0.06"
PRINT DATE: 11/3/2016	SHEET 1 OF 1	DEC X.XXX ± 0.031"
<small>CONFIDENTIAL: THESE DRAWINGS AND COPIES THEREOF REMAIN THE PROPERTY OF JAY-LOR FABRICATING INC. ANY PERSON FOUND UNLAWFULLY USING, DISTRIBUTING, OR IN POSSESSION OF THE ABOVE WILL BE PROSECUTED</small>		

Parts List			
ITEM	PART NUMBER	TITLE	QTY
1	AAB-001-00020	PIN BENT ADJUSTMENT 1/2 X 3-5/8	1
2	AAB-015-40009	GRIP ADJUSTMENT PIN VINYL 1/2 X 2-1/2	1
3	AAB-001-00017	PIN PIVOT 1/2 X 2.41	1
4	AAB-001-00019	PIN HTCH CLIP 1/8 X 2-9/16	2
5	AAA-001-02121-P3	RB (5150/5275) (BLACK)	1

**NOTE: PART QUANTITIES ARE PER RESTRICTOR BLADE
(EACH MIXER HAS 2 BLADES)**

RESTRICTOR BLADES

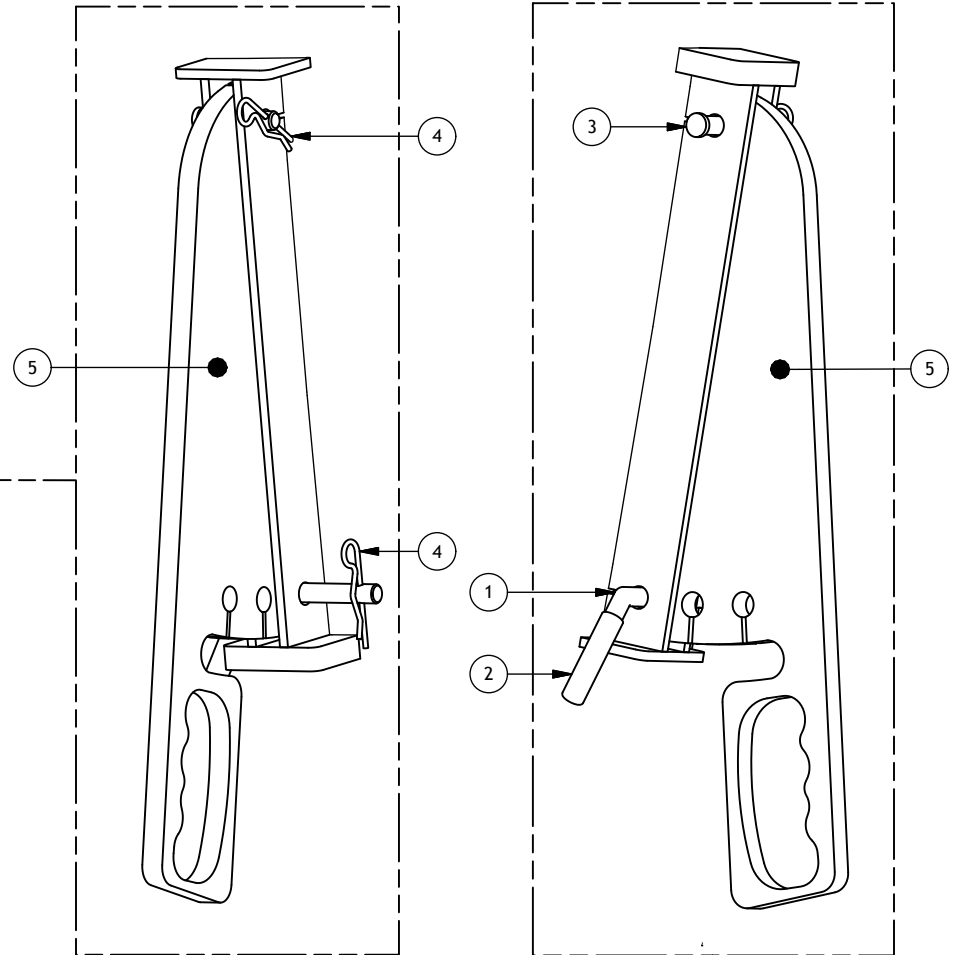
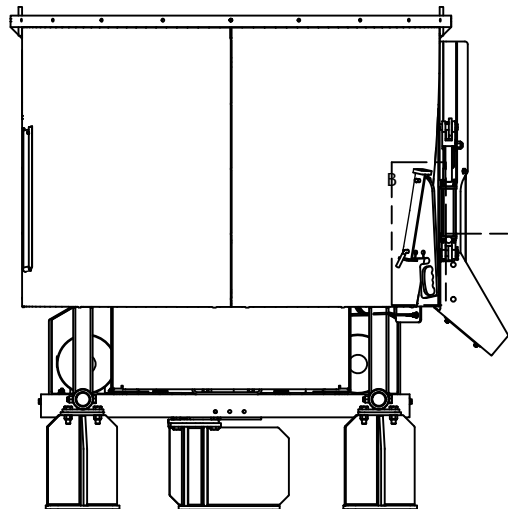
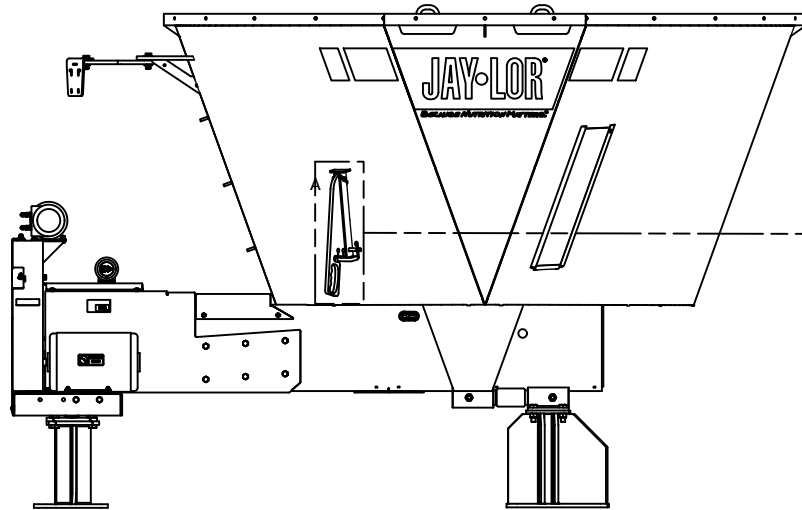

DRAWN : CDiRamio		TOLERANCES (UNLESS SPECIFIED OTHERWISE)
DATE : 8/24/2016		FRACTIONAL ± 1/16"
FILE : AAA-054-00412		DEC X.X ± 0.1"
TITLE : 5150ST RESTRICTOR BLADES		DEC X.XXX ± 0.06"
PRINT DATE: 11/3/2016	SHEET 1 OF 1	DEC X.XXX ± 0.031"
CONFIDENTIAL: THESE DRAWINGS AND COPIES THEREOF REMAIN THE PROPERTY OF JAY-LOR FABRICATING INC. ANY PERSON FOUND UNLAWFULLY USING, DISTRIBUTING, OR IN POSSESSION OF THE ABOVE WILL BE PROSECUTED		ANGULAR ± 0.5°

Parts List

ITEM	PART NUMBER	TITLE	QTY
1	AAB-015-20017	NUT HEX 3/8 UNC GRD 2	34
2	AAB-015-10061	BOLT CARRIAGE 3/8 X 1-1/2 UNC GRD 5	34
3	AAB-015-30012	WSHR FLAT 3/8 USS	34
4	AAB-001-00057	HDPE EXT BLACK/ UV STABILIZED/ 12H X 0.22T X 159L	2

PLASTIC EXTENSION

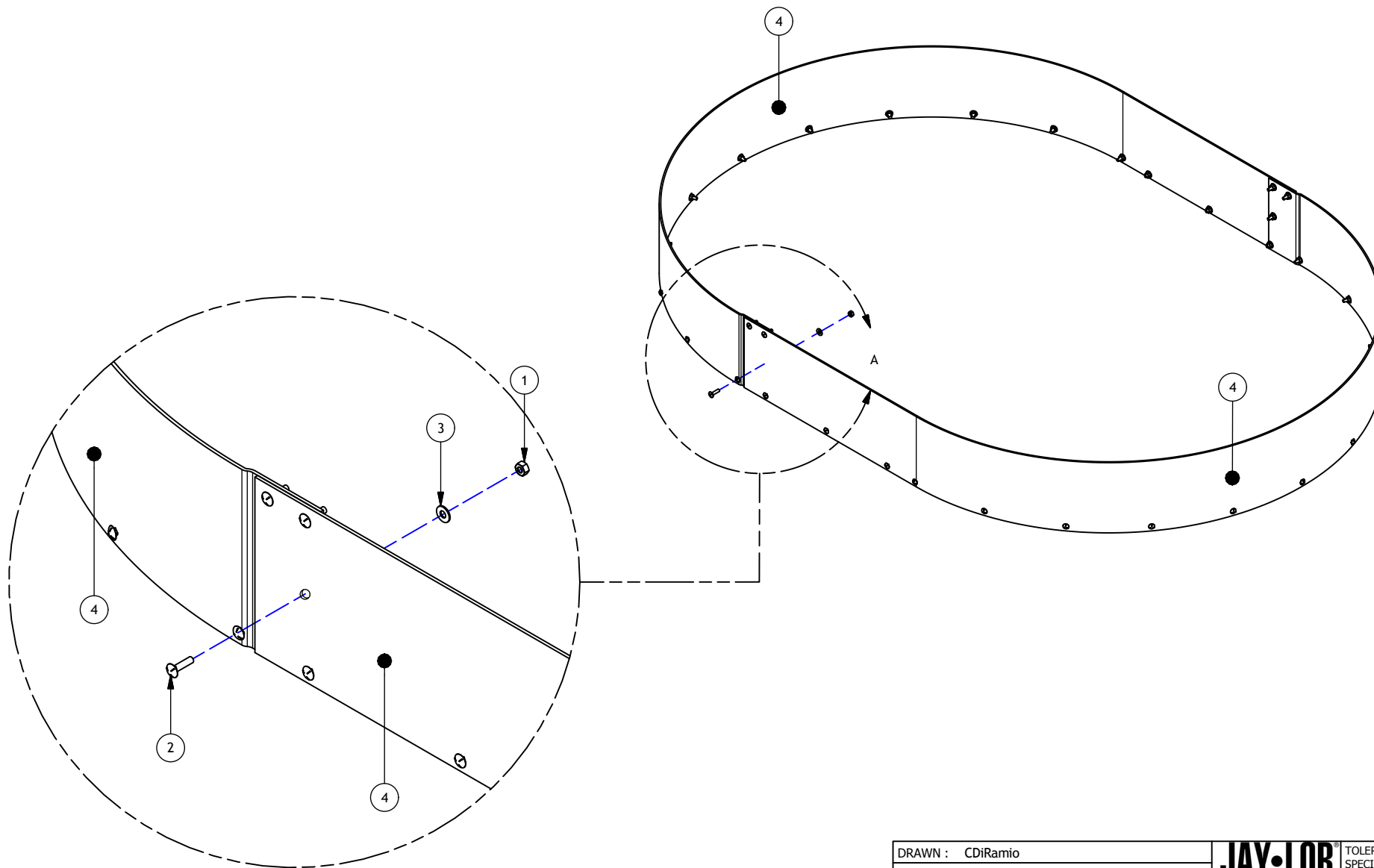

DRAWN : CDiRamio		TOLERANCES (UNLESS SPECIFIED OTHERWISE)
DATE : 8/24/2016		FRACTIONAL ± 1/16"
FILE : AAA-054-00413		DEC X.X ± 0.1"
TITLE : 5150ST PLASTIC EXTENSION		DEC X.XX ± 0.06"
PRINT DATE: 11/3/2016	SHEET 1 OF 1	DEC X.XXX ± 0.031"
CONFIDENTIAL: THESE DRAWINGS AND COPIES THEREOF REMAIN THE PROPERTY OF JAY-LOR FABRICATING INC. ANY PERSON FOUND UNLAWFULLY USING, DISTRIBUTING, OR IN POSSESSION OF THE ABOVE WILL BE PROSECUTED		ANGULAR ± 0.5°

G.FRAME

G

Parts List

ITEM	PART NUMBER	TITLE	QTY
1	AAA-002-02140	DRIVELINE SHEILD (5150ST)	1
2	AAB-015-10028	BOLT HEX 3/8 X 1 UNC	4
3	AAA-002-00442	BELT DRIVE ACCESS COVER 1/8T	1
4	AAA-002-00455	MOTOR SLIDE	2
5	AAA-006-00135	PLASTIC SPCR 1/4T	3
6	AAB-015-10063	BOLT HEX 1/2 X 1-1/2 UNC GRD 5	18
7	AAB-015-20011	NUT HEX 1/2 UNC GRD 5	26
8	AAB-015-30018	WSHR LOCK 1/2	22
9	AAB-015-30013	WSHR FLAT 1/2 USS	10
10	AAB-015-30012	WSHR FLAT 3/8 USS	33
11	AAB-015-30017	WSHR LOCK 3/8	25
12	AAB-015-20017	NUT HEX 3/8 UNC GRD 2	25
13	AAA-006-00352	BOLT HEX FULL THREAD MOD 1/2 X 5 X 13	4
14	AAB-015-10087	BOLT CARRIAGE 1/2 X 1-3/4 UNC GRD 5	4
15	AAB-002-00001	MANUAL HOLDER	1
16	AAB-009-00378	HYD POWER PACK 1 GPM 3 POSITION MANUAL VALVE	1
17	AAB-015-10056	BOLT HEX 3/8 X 1 UNC GRD 2	4
18	AAB-015-10036	BOLT HEX 5/16 X 1 UNC GRD 5	3
19	AAB-015-20035	NUT HEX 5/16-18 LOCK NYLON	3
20	AAA-002-01123	STATIONARY BELT SHROUD 5000 SERIES	1
21	AAA-002-02597	STATIONARY FRAME RAIL 5000 SERIES LTH 1/4T (PAINTED)	1
22	AAA-002-02598	STATIONARY FRAME RAIL 5000 SERIES RTH 1/4T (PAINTED)	1
23	AAA-002-02594	5150 STATIONARY FRAME PLATFORM WELDMENT	1
24	AAB-009-00445	FIT 90DEG 6 FJIC X 6 MJIC	2
25	AAB-009-00713	FIT ADPT 6 MORB X 6 MJIC	2
26	AAB-015-10056	BOLT HEX 3/8 X 1 UNC GRD 2	4

PLATFORM EXTERIOR

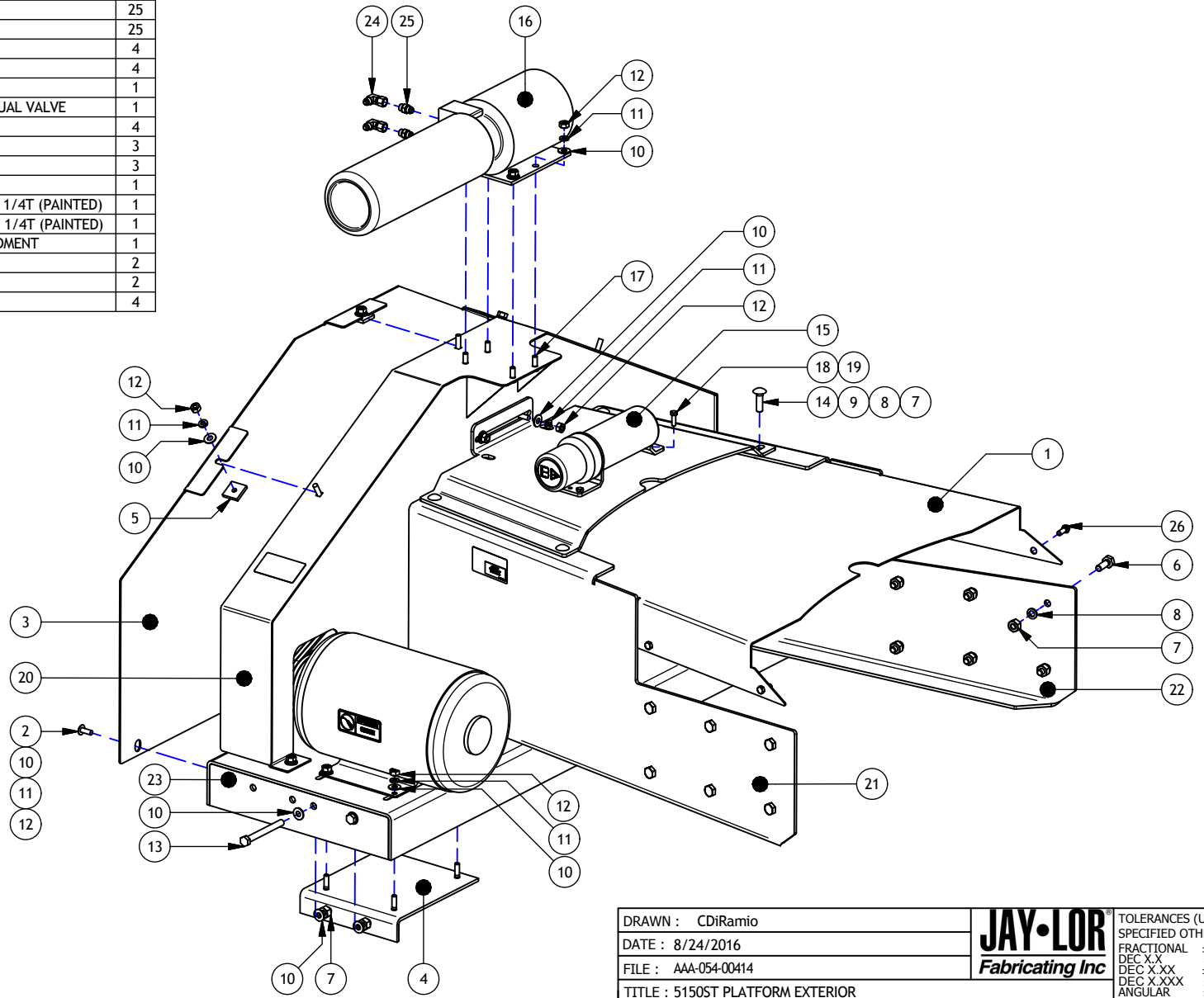

DRAWN : CDiRamio	JAY-LOR Fabricating Inc	TOLERANCES (UNLESS SPECIFIED OTHERWISE)
DATE : 8/24/2016		FRACTIONAL ± 1/16"
FILE : AAA-054-00414		DEC X.X ± 0.1"
TITLE : 5150ST PLATFORM EXTERIOR		DEC X.XX ± 0.06"
		DEC X.XXX ± 0.031"
		ANGULAR ± 0.5°
PRINT DATE: 11/3/2016	SHEET 1 OF 1	
CONFIDENTIAL: THESE DRAWINGS AND COPIES THEREOF REMAIN THE PROPERTY OF JAY-LOR FABRICATING INC. ANY PERSON FOUND UNLAWFULLY USING, DISTRIBUTING, OR IN POSSESSION OF THE ABOVE WILL BE PROSECUTED		

Parts List

ITEM	PART NUMBER	TITLE	QTY
1	AAB-007-00600	ELECTRIC MOTOR 10 HP 220V	2
2	AAB-015-30019	WSHR LOCK 5/8	4
3	AAB-007-00757	PULLY 3-3V900	1
4	AAB-007-00759	6-3V19.00	1
5	AAB-007-00758	3-3V5.00SDS	2
6	AAB-007-00760	3-3V5.00	2
7	AAB-007-00676	V BELT 3-3V900	2
8	AAA-007-00888	KEY STOCK 3/8 X 3/8 X 12L WITH SPLINE GROOVE	1
9	AAA-007-00074	DRIVE SHAFT 1 3/4 20 SP X 1 15/16 KEYED 21-3/4 L W/ 1-3/4 END SHAFT	1
10	AAB-007-00618	DODGE PILLOWBLOCK BEARING 1-15/16DIA	2
11	AAA-002-02600-P3	5275ST/5150ST BEARING MOUNT WELDMENT (PAINTED)	1
12	AAA-002-02594	5150 STATIONARY FRAME PLATFORM WELDMENT	1
13	AAB-015-20059	NUT HEX M16 X 2.00 GRD 8.8	4
14	AAB-015-10121	BOLT HEX 16MM X 65MM GRD 10.9	4
15	AAB-015-10119	BOLT HEX 5/8 X 2.25 UNC GRD 5	4
16	AAB-015-20013	NUT HEX 5/8 UNC GRD 5	4
17	AAA-005-00401	KEY STOCK 1/4 X 1/4 X 1L	2

PLATFORM INTERIOR

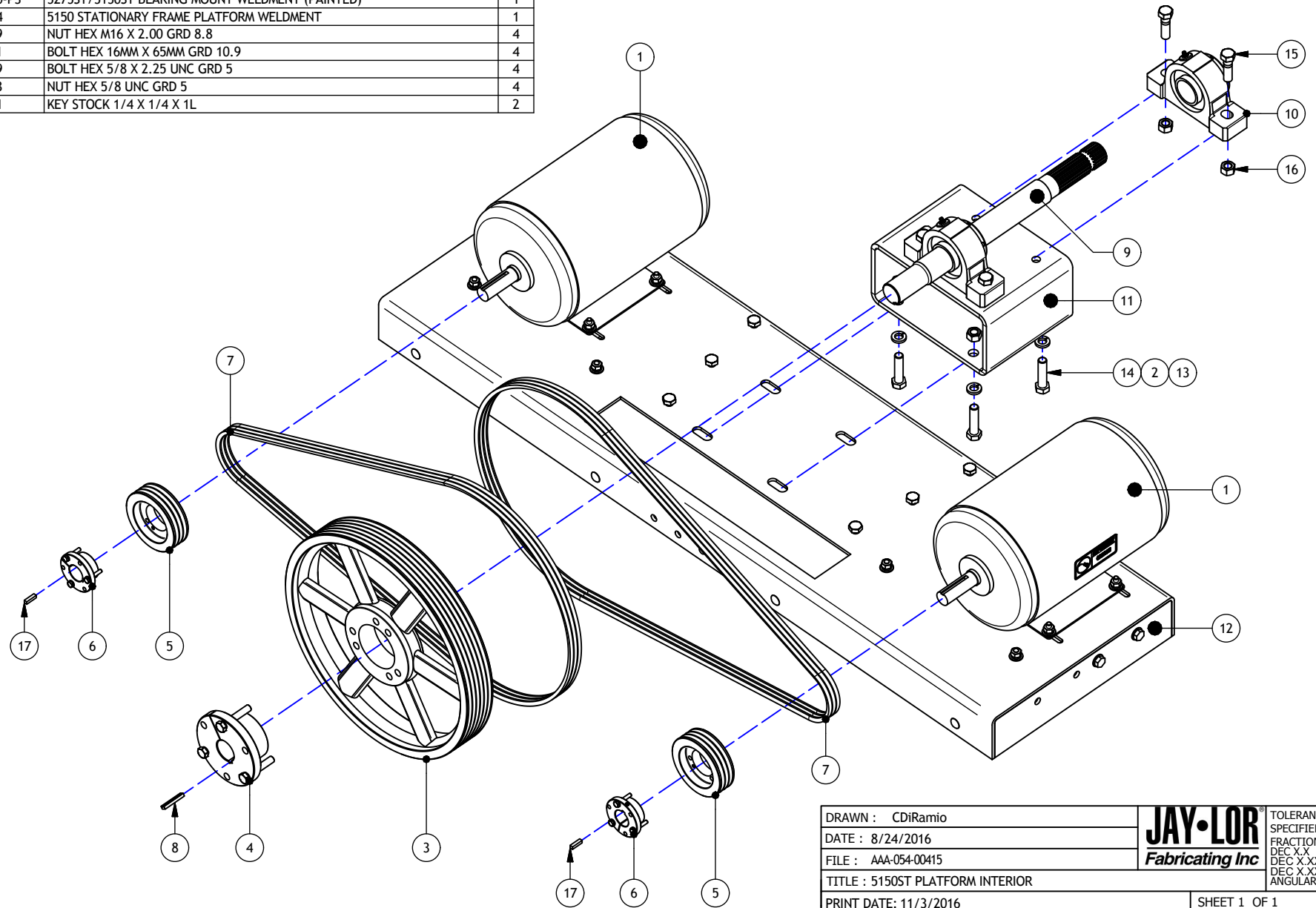

DRAWN : CDiRamio		TOLERANCES (UNLESS SPECIFIED OTHERWISE)
DATE : 8/24/2016		FRACTIONAL ± 1/16"
FILE : AAA-054-00415		DEC X.X ± 0.1"
TITLE : 5150ST PLATFORM INTERIOR		DEC X.XXX ± 0.06"
PRINT DATE: 11/3/2016		DEC X.XXX ± 0.031"
		ANGULAR ± 0.5°
SHEET 1 OF 1		
<small>CONFIDENTIAL: THESE DRAWINGS AND COPIES THEREOF REMAIN THE PROPERTY OF JAY-LOR FABRICATING INC. ANY PERSON FOUND UNLAWFULLY USING, DISTRIBUTING, OR IN POSSESSION OF THE ABOVE WILL BE PROSECUTED</small>		

Parts List			
ITEM	PART NUMBER	TITLE	QTY
1	AAA-002-02605	5150ST SNGL STATIONARY FRT FOOT	1
2	AAA-002-02612	5275 STATIONARY FOOT	2
3	AAA-002-02045	AXLE WB SUPT WELDMENT 2.5ID X 7.125L (5275)	2
4	AAA-002-00453	HITCH BAR MOUNTING PLT	1
5	AAA-002-01125	WB HITCH TUBE WELDMENT 5000 SERIES	1
6	AAB-010-00194	DG WB 2-1/2DIA X 15-1/4L	3
7	AAB-015-30019	WSHR LOCK 5/8	4
8	AAB-015-10040	BOLT HEX 5/8 X 3 UNC GRD 8	4
9	AAB-015-10134	BOLT HEX 3/4 X 2-1/2 UNC GRD 8	12
10	AAB-015-20016	NUT HEX LOCK NYLON 3/4 UNC GRD 8	12

NOTE: PART QUANTITIES ARE PER MACHINE

FEET & MOUNTS

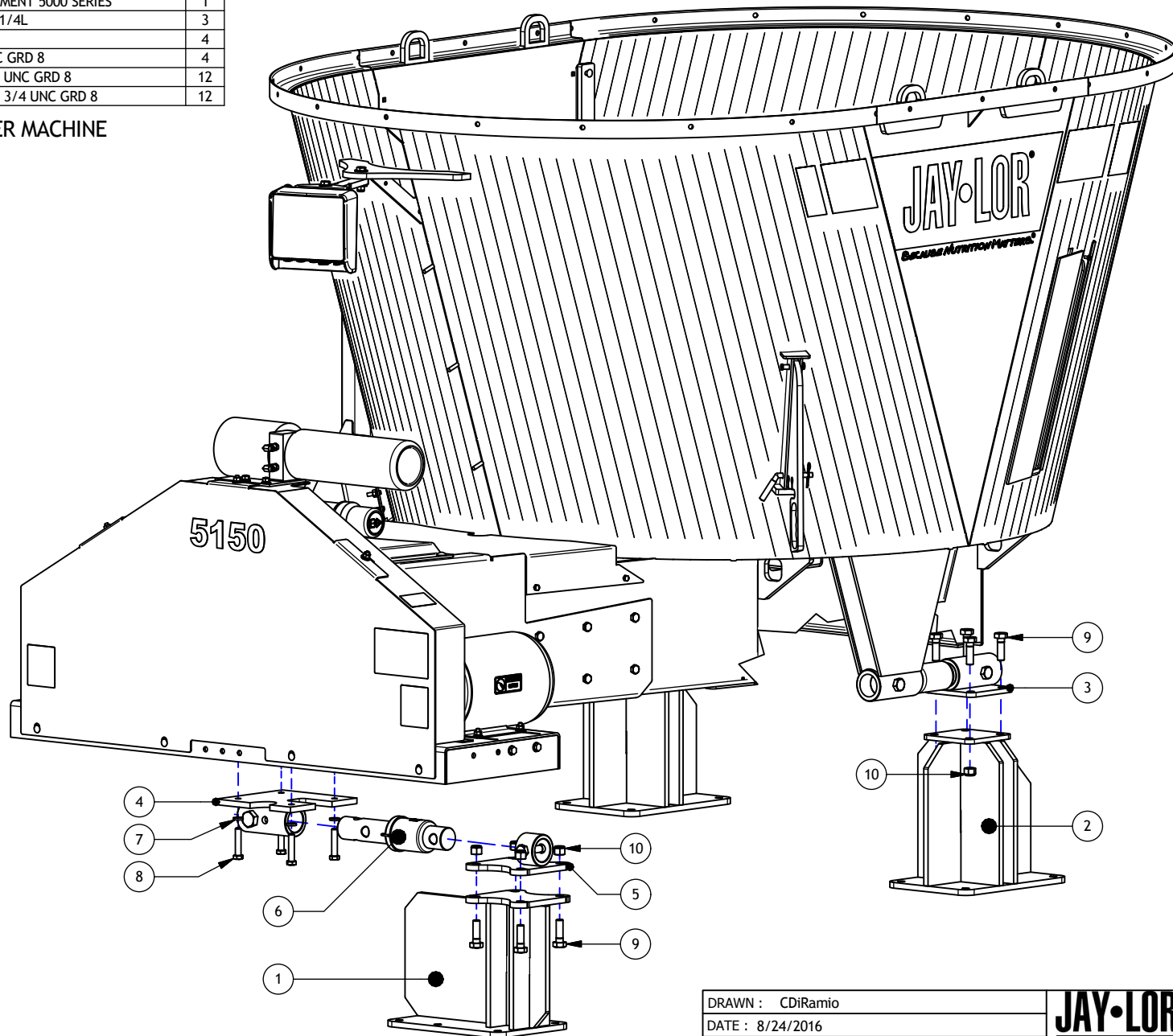

DRAWN : CDiRamio		TOLERANCES (UNLESS SPECIFIED OTHERWISE)
DATE : 8/24/2016		FRACTIONAL ± 1/16"
FILE : AAA-054-00416		DEC X.X ± 0.1"
TITLE : 5150ST FEET & MOUNTS		DEC X.XXX ± 0.06"
PRINT DATE: 2/16/2017		DEC X.XXX ± 0.031"
		ANGULAR ± 0.5°
SHEET 1 OF 1		
<small>CONFIDENTIAL: THESE DRAWINGS AND COPIES THEREOF REMAIN THE PROPERTY OF JAY-LOR FABRICATING INC. ANY PERSON FOUND UNLAWFULLY USING, DISTRIBUTING, OR IN POSSESSION OF THE ABOVE WILL BE PROSECUTED</small>		

H.AUGER

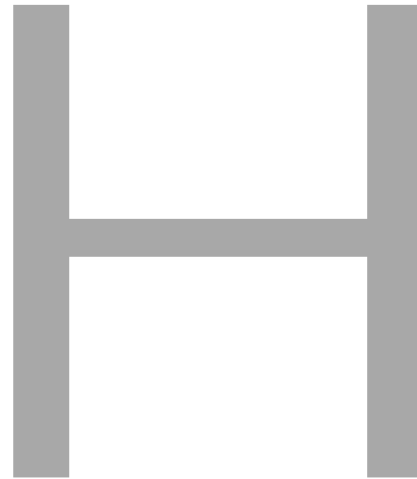

Parts List

ITEM	PART NUMBER	TITLE	QTY
1	AAA-005-00680	5000 SERIES AUGER ASSY 72DIA	1
2	AAA-005-00677	72DIA SLIDE PLATE 1/2T	1
3	AAA-005-00708	BENT & CHAMFERED ANGLING KNIFE 72IN AUGER 410 SS 1/4T	1
4	AAB-005-00030	KNIFE - TUNGSTEN COATED 1/4T (X)	8
5	AAB-015-10066	BOLT CARRIAGE 1/2 X 1-1/2 UNC GRD 5	32
6	AAB-015-20011	NUT HEX 1/2 UNC GRD 5	32

* PART QUANTITIES ARE PER AUGER

Kit List

PART NUMBER	DESCRIPTION
AAA-005-00226	KNIFE KIT INCL KNIFE AND MTG HW (X)
	1 TUNGSTEN COATED KNIFE, 4 CARRIAGE BOLTS (1/2" X 1-1/2"), 4 NUTS (1/2")

AUGER & KNIVES

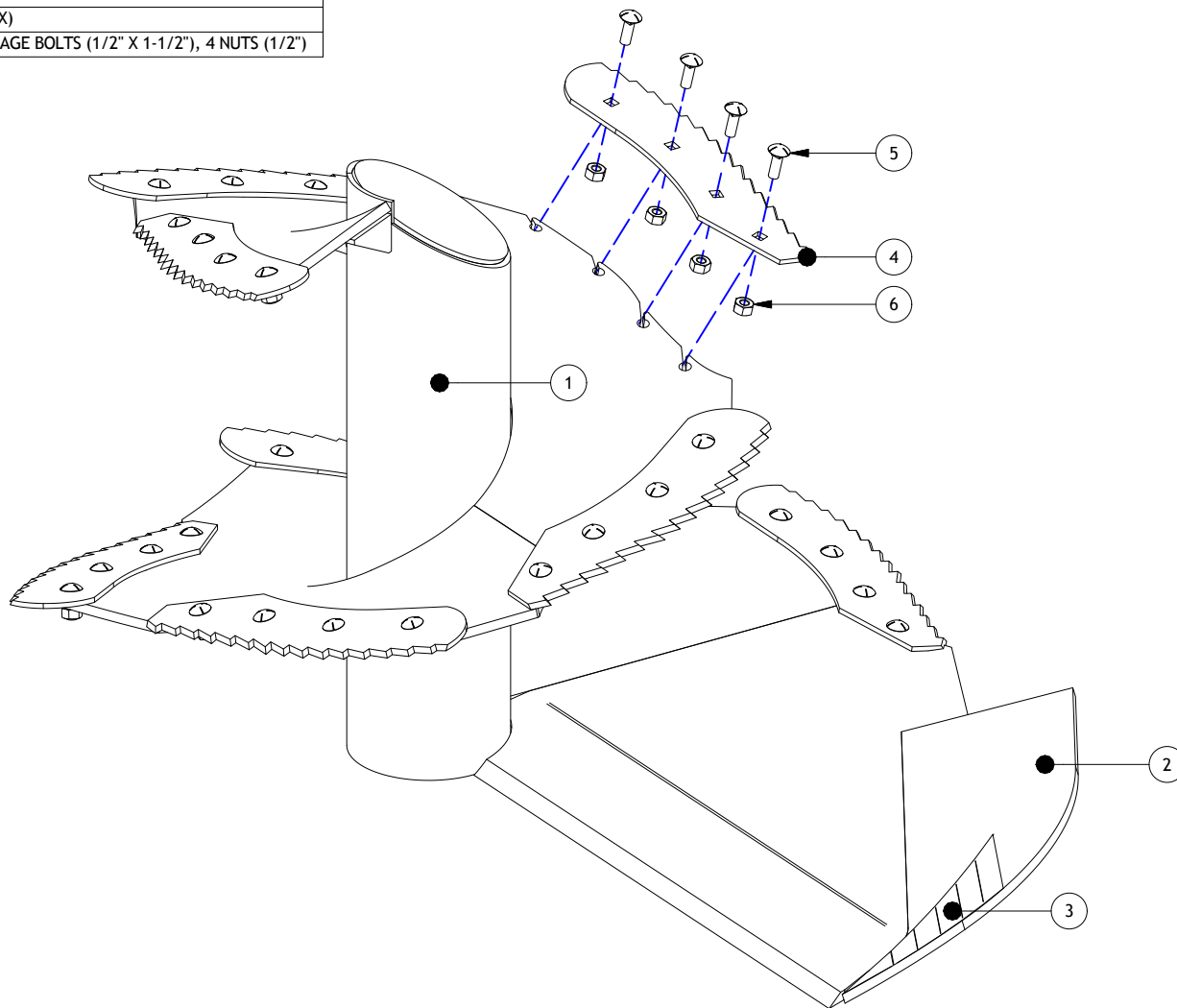

DRAWN : CDiRamio		TOLERANCES (UNLESS SPECIFIED OTHERWISE)
DATE : 8/30/2016		FRACTIONAL ± 1/16"
FILE : AAA-054-00356		DEC X.X ± 0.1"
TITLE : 72IN DIA AUGER & KNIVES		DEC X.XX ± 0.06"
PRINT DATE: 9/26/2016		DEC X.XXX ± 0.031"
		ANGULAR ± 0.5°
SHEET 1 OF 1		
<small>CONFIDENTIAL: THESE DRAWINGS AND COPIES THEREOF REMAIN THE PROPERTY OF JAY-LOR FABRICATING INC. ANY PERSON FOUND UNLAWFULLY USING, DISTRIBUTING, OR IN POSSESSION OF THE ABOVE WILL BE PROSECUTED</small>		

I. DRIVELINE



FRONT PTO

Parts List

ITEM	PART NUMBER	TITLE	QTY
1	AAB-007-01034	NUM 5 PTO INNER YOKE	1
2	AAB-007-01036	NUM 5 PTO ROLL PIN	2
3	AAB-007-01035	NUM 5 PTO OUTER YOKE	1
4	AAB-007-01040	NUM 5 PTO OUTER SHAFT	1
5	AAB-007-01039	NUM 5 PTO INNER TUBE	1
6	AAB-007-01030	NUM 5 PTO CROSS KIT	2
7	AAB-007-01041	NUM 5 PTO YOKE W/ SHEAR BOLT	1
8	AAB-007-01037	NUM 5 PTO 1-3/4F X 20SP	1
9	AAB-007-01029	NUM 5 PTO SHIELD	1

Kit List

PART NUMBER	AAB-007-01025
DESCRIPTION	PTO NUM 5 1-3/8F 6SP X 1-3/4F 20SP W/ SHEAR BOLT
KIT CONTENTS	ALL PARTS IN THE PTO PARTS LIST

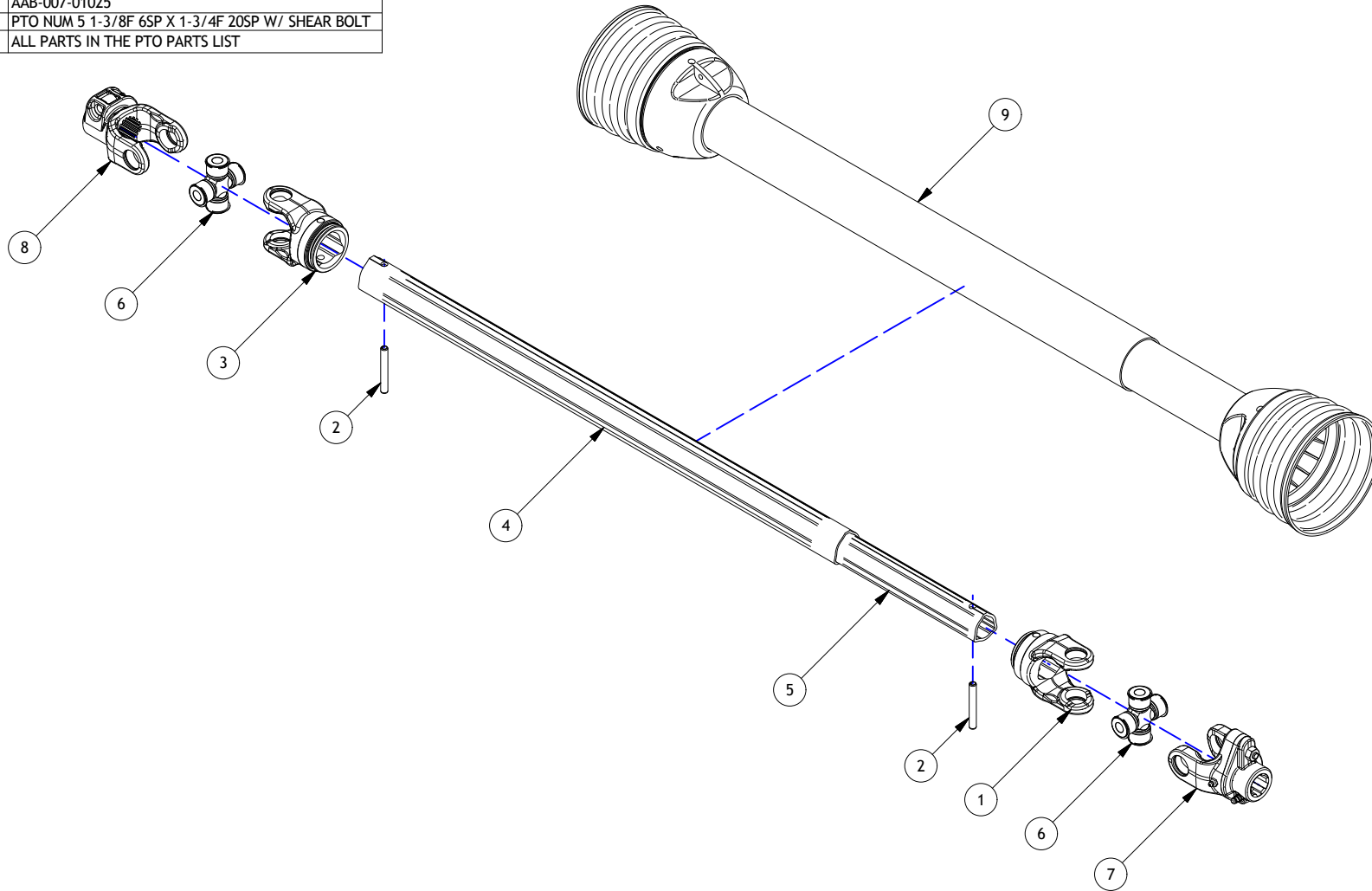

DRAWN : CDiRamio

DATE : 8/30/2016

FILE : AAA-054-00357

TITLE : 5150ST/5275ST FRONT PTO

PRINT DATE: 11/3/2016

JAY-LOR
Fabricating Inc

TOLERANCES (UNLESS SPECIFIED OTHERWISE)
 FRACTIONAL ± 1/16"
 DEC X.X ± 0.1"
 DEC X.XX ± 0.06"
 DEC X.XXX ± 0.031"
 ANGULAR ± 0.5°

SHEET 1 OF 1

CONFIDENTIAL: THESE DRAWINGS AND COPIES THEREOF REMAIN THE PROPERTY OF JAY-LOR FABRICATING INC. ANY PERSON FOUND UNLAWFULLY USING, DISTRIBUTING, OR IN POSSESSION OF THE ABOVE WILL BE PROSECUTED

OIL RESERVOIR

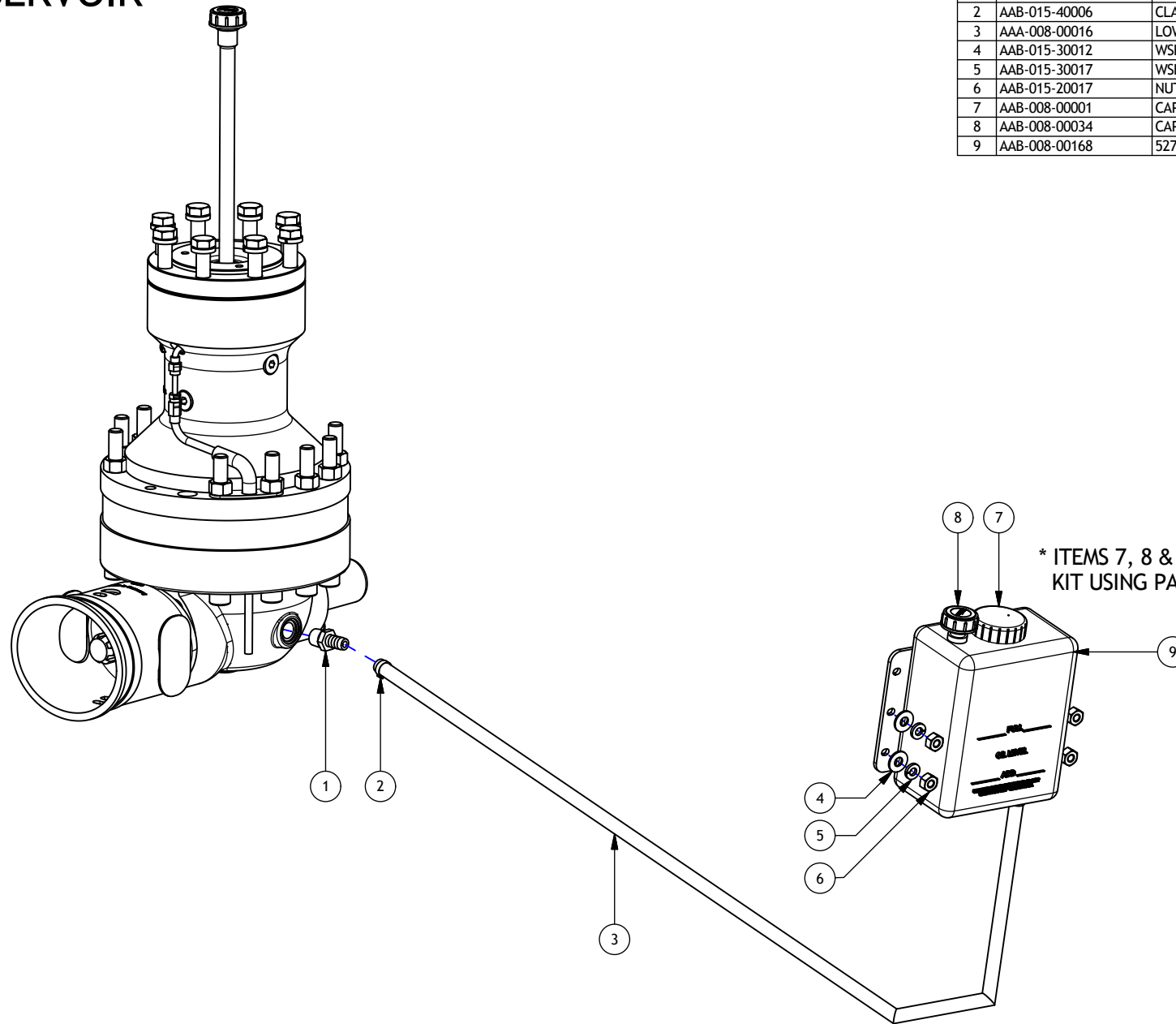

Parts List

ITEM	PART NUMBER	TITLE	QTY
1	AAB-008-00127	FIT 8 MNPT X 1/2 BARB	1
2	AAB-015-40006	CLAMP ONE EAR 11/16	2
3	AAA-008-00016	LOWER OIL RESERVIOR HOSE 3/8 X 7.5FT	1
4	AAB-015-30012	WSHR FLAT 3/8 USS	4
5	AAB-015-30017	WSHR LOCK 3/8	4
6	AAB-015-20017	NUT HEX 3/8 UNC GRD 2	4
7	AAB-008-00001	CAP VENTED PLASTIC RSVR 2-1/4DIA	1
8	AAB-008-00034	CAP BREATHER ACRYLIC RSVR	1
9	AAB-008-00168	5275/5150 OIL RSVR 3QT PLASTIC TNK	1

* ITEMS 7, 8 & 9 CAN BE ORDERED AS A KIT USING PART # AAB-008-00169

DRAWN : CDiRamio		TOLERANCES (UNLESS SPECIFIED OTHERWISE)
DATE : 3/21/2017		FRACTIONAL ± 1/16"
FILE : AAA-054-00359		DEC X.X ± 0.1"
TITLE : 5150ST/5275ST GEARBOX OIL RESERVOIR		DEC X.XX ± 0.06"
PRINT DATE: 3/21/2017	SHEET 1 OF 1	DEC X.XXX ± 0.031"
CONFIDENTIAL: THESE DRAWINGS AND COPIES THEREOF REMAIN THE PROPERTY OF JAY-LOR FABRICATING INC. ANY PERSON FOUND UNLAWFULLY USING, DISTRIBUTING, OR IN POSSESSION OF THE ABOVE WILL BE PROSECUTED		ANGULAR ± 0.5°

GEARBOX EXTERIOR

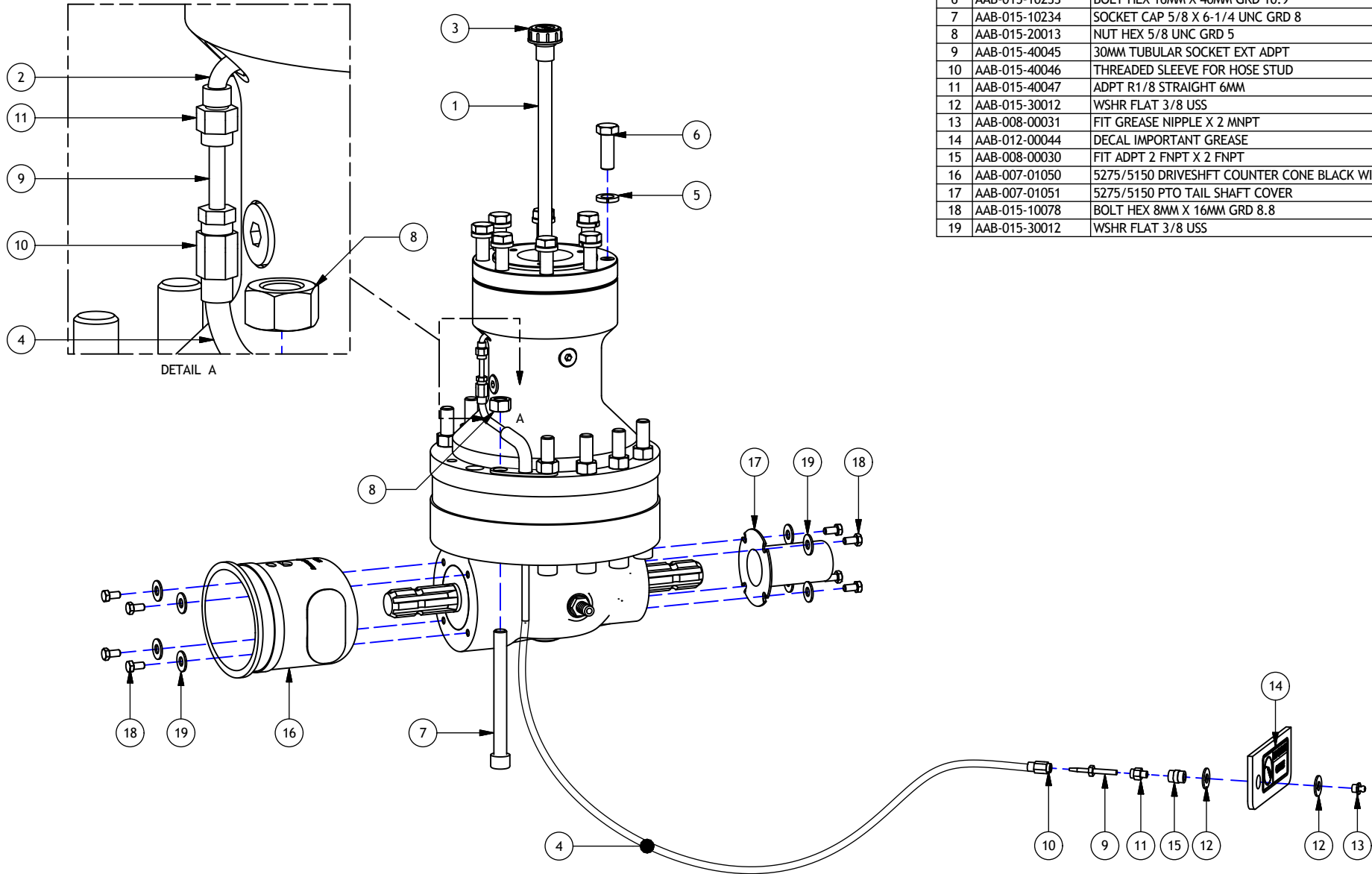

Parts List

ITEM	PART NUMBER	TITLE	QTY
1	AAB-008-00124	STL BREATHER EXTENSION 12L (MALE 3/8G - 6 FNPT)	1
2	AAB-008-00164	O4061589 G1/8 PUSHLOCK 6MM	1
3	AAB-008-00034	CAP BREATHER ACRYLIC RSVR	1
4	AAB-008-00166	840BAR 6MM GREASE LINE (100120200)	1
5	AAB-015-30019	WSHR LOCK 5/8	8
6	AAB-015-10233	BOLT HEX 16MM X 40MM GRD 10.9	8
7	AAB-015-10234	SOCKET CAP 5/8 X 6-1/4 UNC GRD 8	10
8	AAB-015-20013	NUT HEX 5/8 UNC GRD 5	10
9	AAB-015-40045	30MM TUBULAR SOCKET EXT ADPT	1
10	AAB-015-40046	THREADED SLEEVE FOR HOSE STUD	1
11	AAB-015-40047	ADPT R1/8 STRAIGHT 6MM	1
12	AAB-015-30012	WSHR FLAT 3/8 USS	2
13	AAB-008-00031	FIT GREASE NIPPLE X 2 MNPT	1
14	AAB-012-00044	DECAL IMPORTANT GREASE	1
15	AAB-008-00030	FIT ADPT 2 FNPT X 2 FNPT	1
16	AAB-007-01050	5275/5150 DRIVESHAFT COUNTER CONE BLACK WITH FLAPS	1
17	AAB-007-01051	5275/5150 PTO TAIL SHAFT COVER	1
18	AAB-015-10078	BOLT HEX 8MM X 16MM GRD 8.8	8
19	AAB-015-30012	WSHR FLAT 3/8 USS	8

DRAWN : CDiRamio	JAY-LOR Fabricating Inc	TOLERANCES (UNLESS SPECIFIED OTHERWISE) FRACTIONAL ± 1/16" DEC X.X ± 0.1" DEC X.XX ± 0.06" DEC X.XXX ± 0.031" ANGULAR ± 0.5°
DATE : 3/20/2017		
FILE : AAA-054-00360 NEW	TITLE : 5150ST/5275ST GEARBOX HARDWARE & GREASE LINE	
PRINT DATE: 3/20/2017	SHEET 1 OF 1	
CONFIDENTIAL: THESE DRAWINGS AND COPIES THEREOF REMAIN THE PROPERTY OF JAY-LOR FABRICATING INC. ANY PERSON FOUND UNLAWFULLY USING, DISTRIBUTING, OR IN POSSESSION OF THE ABOVE WILL BE PROSECUTED		

J. SCALE

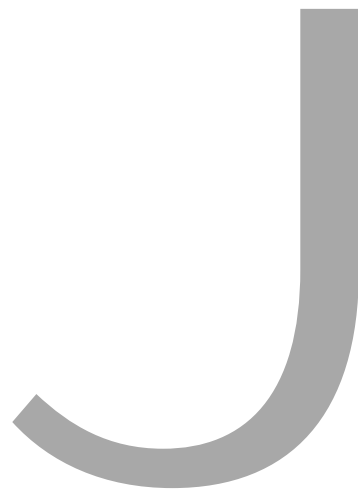
A large, bold, gray letter 'J' is centered on the page. The letter is a simple, sans-serif style with a thick stroke. It has a vertical stem on the right side that curves at the bottom into a hook that extends to the left.

Parts List

ITEM	PART NUMBER	TITLE	QTY
1	AAB-010-00419	DG WB 2.5 DIA X 16.929 L	2
2	AAA-010-00048	SCALE HEAD MNT BRKT 1/4T	1
3	AAB-015-20019	NUT NYLON LOCK 1/2 UNC GRD 5	2
4	AAB-015-30013	WSHR FLAT 1/2 USS	4
5	AAB-015-10064	BOLT HEX 1/2 X 2 UNC GRD 5	2
6	AAA-002-00995	SCALE HEAD SWING ARM 5/8T (PAINTED)	1
7	AAB-000-00004	TPR RUBR WSHR 1-1/2OD X 1/2ID X 1/8T BLACK	2
8	AAB-010-00197	DG INDICTR - STAD 04	1
9	AAB-010-00194	DG WB 2-1/2DIA X 15-1/4L	1

SCALE SYSTEM

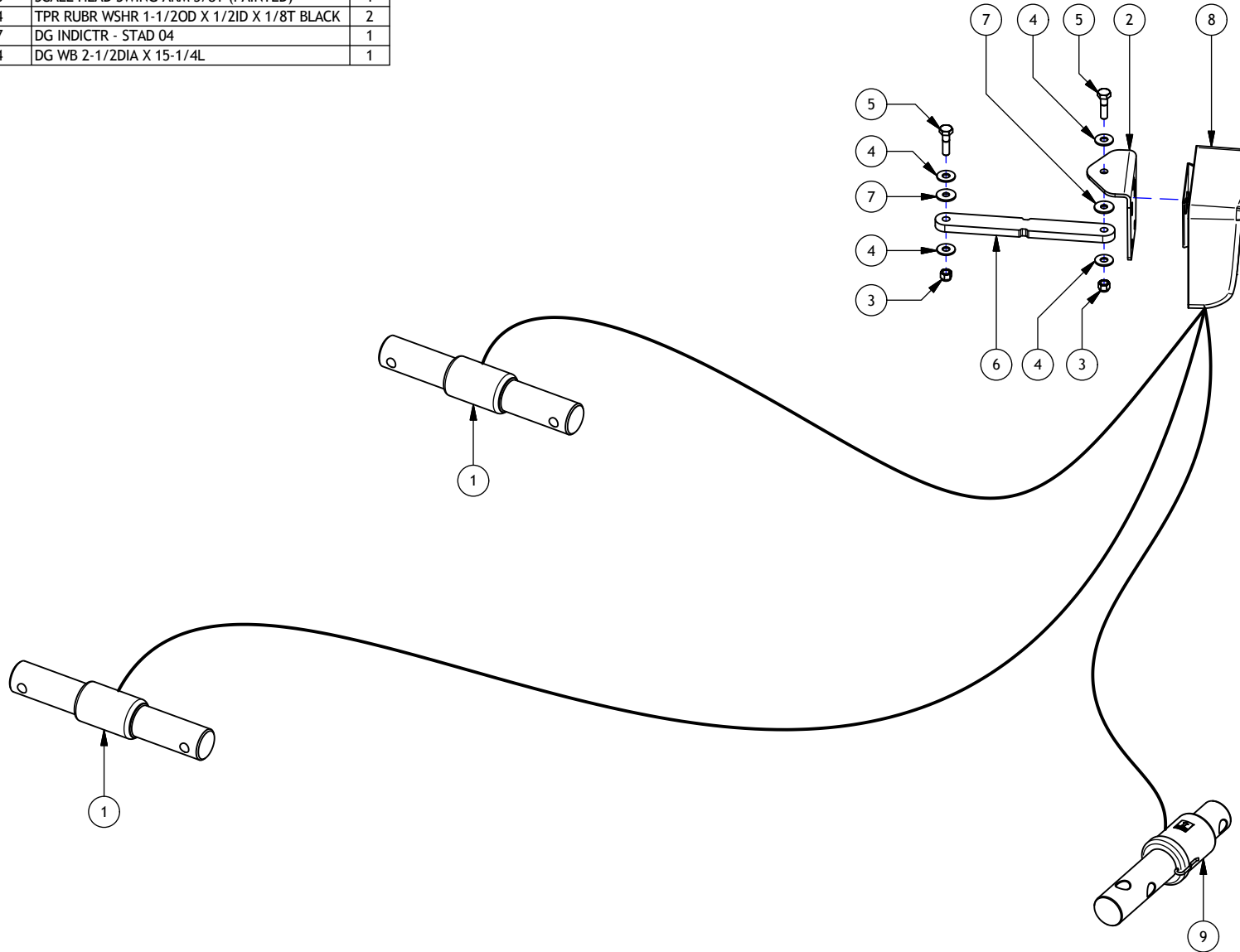

DRAWN : CDiRamio		TOLERANCES (UNLESS SPECIFIED OTHERWISE)
DATE : 8/30/2016		FRACTIONAL ± 1/16"
FILE : AAA-054-00417		DEC X.X ± 0.1"
TITLE : 5150ST SCALE SYSTEM		DEC X.XX ± 0.06"
PRINT DATE: 11/4/2016	SHEET 1 OF 1	DEC X.XXX ± 0.031"
CONFIDENTIAL: THESE DRAWINGS AND COPIES THEREOF REMAIN THE PROPERTY OF JAY-LOR FABRICATING INC. ANY PERSON FOUND UNLAWFULLY USING, DISTRIBUTING, OR IN POSSESSION OF THE ABOVE WILL BE PROSECUTED		ANGULAR ± 0.5°